

230 SOLAR PANEL

EXCEPTIONAL EFFICIENCY AND PERFORMANCE

BENEFITS

Highest Efficiency

Panel efficiency of 18.5% is higher than any commercially available panel of similar size

More Power

Delivers up to 50% more power per unit area than conventional solar panels and 100% more than thin film solar panels

Reduces Installation Cost

More power per panel means fewer panels per install. This saves both time and money.

Reliable and Robust Design

Proven materials, tempered front glass, and a sturdy anodized frame allow panel to operate reliably in multiple mounting configurations



The SunPower 230 Solar Panel provides today's highest efficiency and performance. Utilizing 72 next generation SunPower all-back contact solar cells and an optimized panel design, the SunPower 230 delivers an unprecedented total panel conversion efficiency of 18.5%. The 230 panel's reduced voltage-temperature coefficient and exceptional low-light performance attributes provide far higher energy delivery per peak power than conventional panels.

SunPower's High Efficiency Advantage - Up to Twice the Power

Comparable systems covering 1000 m² / 10,750 ft²

	Thin Film	Conventional	SunPower
Watts / Panel	65	165	230
Efficiency	9.0%	12.0%	18.5%
kWs	90	120	185

Electrical Data

Measured at Standard Test Conditions (STC): irradiance of 1000/m², air mass 1.5 g, and cell temperature 25° C

Peak Power (+/-5%)	Pmax	230 W
Rated Voltage	Vmp	41.0 V
Rated Current	Imp	5.61 A
Open Circuit Voltage	Voc	48.7 V
Short Circuit Current	Isc	5.99 A
Maximum System Voltage	IEC, UL	1000 V, 600 V
Temperature Coefficients		
	Power	-0.38% /°C
	Voltage (Voc)	-132.5 mV/°C
	Current (Isc)	3.5 mA/°C
Series Fuse Rating		20 A
Peak Power per Unit Area		185 W/m ² , 17.2 W/ft ²
CEC PTC Rating		213.5 W

Mechanical Data

Solar Cells	72 SunPower all-back contact monocrystalline
Front Glass	3.2mm (1/8 in) tempered
Junction Box	IP-65 rated with 3 bypass diodes
Output Cables	900 mm length / Multi-Contact connectors
Frame	Anodized aluminum alloy type 6063
Weight	15 kg, 33 lbs

IV Curve

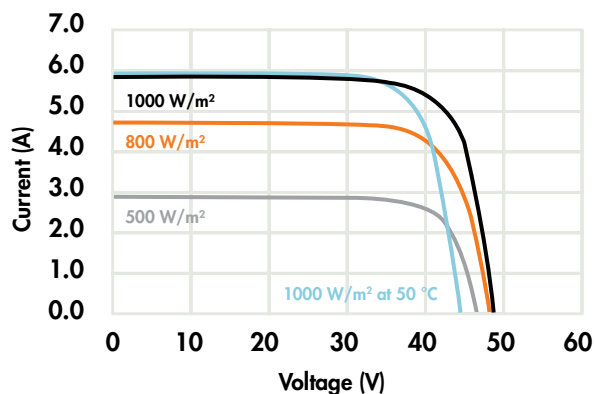

Current/voltage characteristics with dependence on irradiance and module temperature.

Tested Operating Conditions

Temperature	-40° C to +85° C (-40° F to +185° F)
Max load	50 psf (2400 Pascals) front and back
Impact Resistance	Hail - 25mm (1 in) at 23 m/s (52 mph)

Warranty and Certifications

Warranty	25 year limited power warranty 10 year limited product warranty
Certifications	IEC 61215, Safety tested IEC 61730; Tested to UL 1703 by UL or CSA, Class C Fire Rating

Dimensions

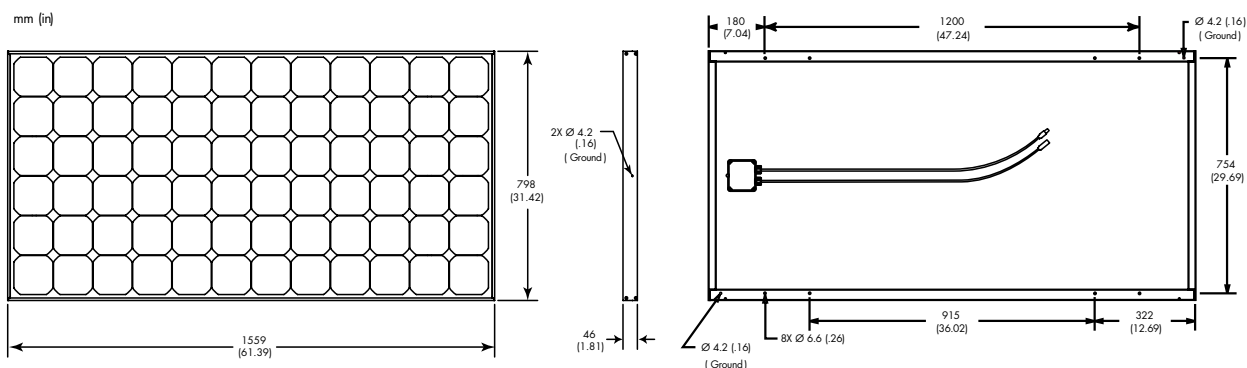

CAUTION: READ SAFETY AND INSTALLATION INSTRUCTIONS BEFORE USING THE PRODUCT. Go to www.sunpowercorp.com/panels for details

About SunPower

SunPower designs, manufactures and delivers high-performance solar electric technology worldwide. Our high-efficiency solar cells generate up to 50 percent more power than conventional solar cells. Our high-performance solar panels, roof tiles and trackers deliver significantly more energy than competing systems.